

Pump Manual

Lubecore_GM_010

Hydraulic-Powered

Lubrication System



lubecore™

Document Information

Title: General Manual Lubecore Hydraulic-Powered Lubrication System

File ref: Lubecore_GM_010

Revision: 1

Publication date: December 2020

Revisions:

TRADEMARKS

Lubecore is a trademarked name. Whether Lubecore appears in this document as Lubecore™, Lubecore, Lubecore International or lubecore, all instance of the name are considered trademarked and cannot be used without the express permission of Lubecore International.

All rights reserved. No part of this publication may be copied and/or published by any means without obtaining prior written permission from Lubecore™. Due to continuous product development and improvement Lubecore reserves the right to update parts at any time, the contents of this manual may also be changed without prior notice. This manual applies to the standard version of the product. Lubecore cannot accept liability for any damage arising from the use of this publication. Please contact Lubecore in case of any questions related to the revision of, required service, repairs and or maintenance as described in this publication.

Table of Contents

Hydraulic-Powered	Error! Bookmark not defined.
Lubrication System	1
Document Information	2
Preface to the Manual.....	5
Safety Precautions.....	6
Introduction	7
The Concept of Automated Lubrication	8
Hydraulic-Powered Lubrication System.....	10
Pump Overview	10
Envelope	11
Operating Principle.....	12
Platform Interfaces & Requirements	13
Hydraulic Pressure Requirements	13
Hydraulic Interfaces	15
Inlet Hose.....	15
Mounting Interfaces	15
Optional Low-Level Sensor.....	16
Wiring Schematic	17
Metering Element Sizing	18
Greasing System Output Pressure	19
Pressure Relief Valve.....	19
System Layouts.....	20
System Size Limitations	20
Installation Guide.....	21
Mounting Bracket Options	25
Low-Profile Standard Bracket	25
High-Profile Standard Bracket	26
Cylinder Mount Brackets.....	27
Weld-On Plate.....	27
Maintenance Procedure	28
Trouble Shooting a Progressive Automatic Greasing System.....	29
Available Options	31
How to Order	32
Option 1.....	32
Option 2.....	32

Illustrated Parts List.....	33
Trouble Shooting Guide	37

Preface to the Manual

The operation instructions contain important information for the safe and proper operation of an Automated Lubrication System. It is recommended that a user read the instructions carefully before operation, Lubecore will not be held liable for damages and failures resulting from non-observance of these instructions. All instructions must be completed respective to national regulations pertaining to accident and environmental protection.

Disclaimer:

Lubecore International reserves the right to modify, correct, update, expand or delete items, descriptions, directions, explanations from this document without prior or direct notification of distributors, customers, dealers, end-users or persons whether spoken or written.

All rights reserved:

This document is the property of Lubecore International, Inc. No part of this document may be reproduced or altered, copied and/or published by means of printing, photocopying, microfilm, scanning or any other form of electronic means without prior written permission from Lubecore International, Inc. This applies to all drawings, diagrams, charts, schedules etc. You are requested to contact Lubecore technical department for information concerning items not discussed in this document. Whilst this document has been prepared with the greatest possible care Lubecore International, Inc. cannot accept responsibility for errors and/or omissions.

Responsibility to ensure the safe operation of the Automated Lubrication System:

The end-user is responsible for the following:

- 1). The Automated Lubrication System shall be operated only for the intended use and its design shall neither be modified nor transformed.
- 2). The Automated Lubrication System shall be operated properly only if it is in a proper functioning condition and if it is operated in accordance with the maintenance requirements.
- 3). Personnel must be familiar with this operation manual and the safety instructions mentioned herein and observe these carefully.
- 4). Wastes (e.g. used oil, detergents, lubricant) must be disposed of in accordance with relevant federal, state, provincial and territorial environmental regulations.

Service:

Lubecore offers users full service in the form of advice, on-site installation assistance, training, etc. if requested. In case of inquiries pertaining to maintenance, repairs and parts, Lubecore requires model-specific data to enable us to identify the components of the Automated Lubrication System. Lubecore will not accept any liability for damages caused by the misuse of the designed Automated Lubrication System and/or the repair of said system by using any other parts other than Lubecore International original (OEM) parts.

Safety Precautions

- 1) Comply with all safety regulations applicable within the locality where all work is performed.
- 2) Always take the necessary precautions to prevent potentially dangerous situations from occurring during installation, inspection and maintenance. Always apply or use adequate safety measures to prevent personal injury and material damage, before starting work on any piece of the equipment.
- 3) The electrical system of the equipment must be disconnected before any work is performed.
- 4) The pressurized air system of the equipment must be drained of all air and pressure.
- 5) Inquire with the facilities management about the prescribed procedure to immobilize equipment and prevent the operation of equipment. When these are not prescribed, remove any means that can start the equipment (ignition key / main power switch) and place indicator tags to show others not to start the equipment.
- 6) Never work underneath a machine, vehicle or any other piece of equipment, which is raised by a jack only. Always use a jack stand and check that the ground is firm and sufficiently flat.
- 7) Keep in mind that a vehicle with air suspension may drop of its own accord.
- 8) Only work underneath a cab if it is fully tilted and latched, or otherwise secured preventing accidental return-tilt.
- 9) Disconnect the ground battery lead from the vehicle's battery. This prevents electrical equipment from being inadvertently activated or otherwise electrically damaged.
- 10) Avoid working on a machine, vehicle or other equipment that recently was in use. Give time to allow components to cool (coolant, exhaust, turbo, etc.).
- 11) A vehicle, machine or other equipment may only be operated by those who are trained and licensed to do so and are aware of all possible dangers.
- 12) Only use tools that fit and are designed for the specific task.
- 13) Adhere to all regulations, specifications and limitations as specified by the manufacturer of the machine, vehicle, equipment and /or engine.
- 14) Keep the environment in which you work clean for yourself and others.

Introduction

Lubecore™ Automated Lubrication Systems take care of daily regular and preventive maintenance for components requiring lubrication.

An Automated Lubrication System prevents unnecessary wear and downtime, thus reducing operating costs and preventing unforeseen expenses.

Automated Lubrication Systems not only assist with extending maintenance intervals but also prolong the useful technical and economic life of the equipment thus providing a higher residual value.

Lubecore Automated Lubrication Systems are environmentally friendly; they are suitable for biodegradable lubricants and prevent manual over-lubrication, and grease waste. The reduced need for replacement components also has a positive impact on the environment reducing the need for raw materials and energy to produce these replacement components.

The most important advantages:

- Extension of maintenance intervals.
- Reduced wear on components.
- Lower repair and replacement costs.
- Prevents downtime.
- More effective use of lubricant.
- Less time spent by technicians servicing equipment.
- Less expensive lubricant required as expensive additives can be avoided.
- Reduces strain on equipment and operator.
- Improved fifth wheel performance; avoid trailer-steer and improves safety.
- Promotes the use of a single type of lubricant, preventing compatibility problems and the accidental application of the incorrect type of grease.

A Lubecore Automated Lubrication System ensures that all connected lubrication points on a vehicle or equipment are lubricated with a predetermined amount of grease at the correct interval. As lubrication takes place while the vehicle is in use, the lubricant is dispensed to all the connected lubrication points during the movement of those components that are connected, ensuring an improved distribution of the lubricant over the surface area.

Apart from refilling the grease reservoir and performing a periodic quick system inspection, the Lubecore Automated Lubrication System does not require anything else to get the job done.

Lubecore's Automated Lubrication Systems are designed with the utmost care and tested rigorously. This ensures extended operational life and trouble-free operation, even under extreme operating conditions.

High Lubecore installation standards along with the use of the correct type of grease and periodic inspections ensure years of trouble-free system operation. Periodic inspections, which take little time and effort, can be performed during the regular daily circle check by the operator as well as monthly by the maintenance staff.

The Concept of Automated Lubrication

Greases are used where a mechanism can only be lubricated infrequently and where a lubricating oil would not stay in position. They also act as valuable sealants to prevent the ingress of water and dust.

Equipment requires lubrication for the following reasons:

- 1) Keep moving components separated.

Lubricants are typically used to separate moving components, reducing friction, surface fatigue, heat generation, operating noise and vibrations. The most common way lubricants achieve this is by creating a physical barrier. In cases of high surface pressure (EP) or temperatures, the fluid film is thin and some of the forces are transmitted between the surfaces through the lubricant. This is termed elastohydrodynamic lubrication.

- 2) Carry away contaminants and debris (“Wash Out” or “Purge”).

Any accidental metal-to-metal contact created by debris or externally introduced contaminants like dirt or water, need to be removed to reduce the risk of damage and prevent corrosion.

- 3) Protect against wear.

Lubricants do not just prevent wear by keeping the moving parts apart. Lubricants may also contain anti-wear or extreme pressure additives to boost their performance against wear and fatigue.

- 4) Prevent corrosion.

Quality lubricants are typically formulated with additives that form chemical bonds with surfaces to prevent corrosion and rust.

Under normal circumstances, lubricants/greases are applied to moving parts using a manual grease gun during regular maintenance intervals. These maintenance intervals could coincide with other service requirements like engine oil changes or can be determined based on hours of operation.

Proper equipment maintenance incorporates OEM-recommended lubricant application at regular intervals. The goal is to ensure that the protective grease film is preserved between moving surfaces. The required interval (hours of operation or mileage) is determined by the user operating information, equipment type, and environmental conditions. The equipment owner/operator is responsible to review the equipment and the lubricant application interval and adjust as needed to refresh the lubricant and prevent premature wear.

The manual application of lubricant relies on flush out of old lubricant in one instance during a service interval, while the equipment is idle. The goal is to prevent the failure of the lubricant film, as mentioned earlier, to prevent metal-to-metal contact.

Benefits

Automated Lubrication Systems by Lubecore™ are designed to ensure the proper quantity of lubricant is applied during equipment operation ensuring the better distribution of lubricant to moving parts, increasing the longevity and reliability of the equipment being lubricated. Automated Lubrication Systems (ALS) provide a higher frequency of lubricant application with nominal quantities of lubricant to sustain the lubrication film while the equipment is in operation. This ensures proper protection without over greasing and unnecessary waste.

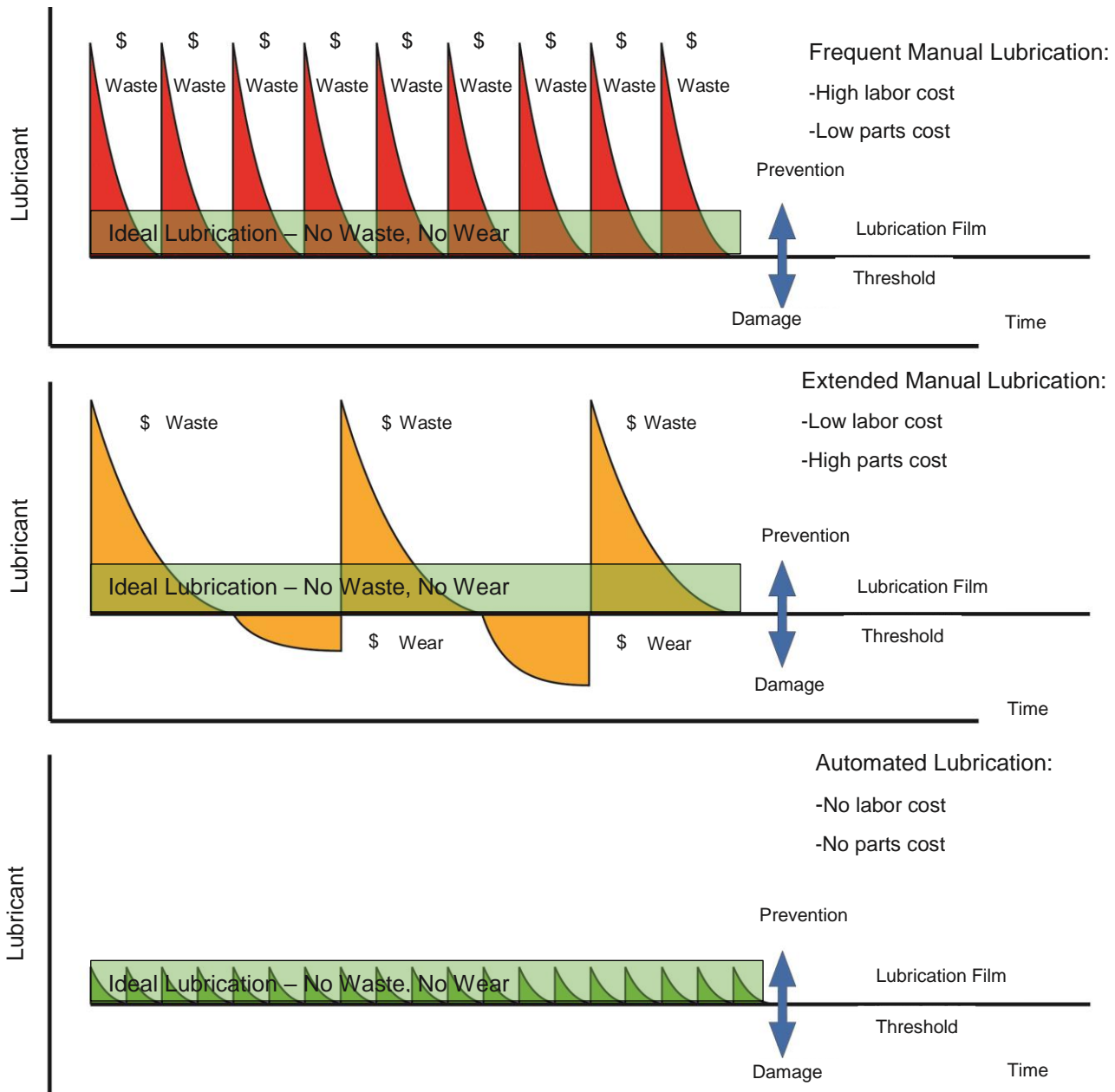

Figure 1 - Manual Versus Automatic Lubrication, Representation of Concept

Hydraulic-Powered Lubrication System

Pump Overview

The Lubecore hydraulic-powered lubrication system is designed to feed a progressive lubrication distribution system. For more details on how a progressive system works, refer to Lubecore general manual 013, “Modular Progressive Automated Lubrication System”

The Lubecore hydraulic-powered lubrication system is shown in **Figure 2**. A full pump assembly comprises a grease tube holder similar to that found on a manual grease gun, a metering element, bleed screw, return port, low-level sensor, mounting hardware, and hydraulic port.

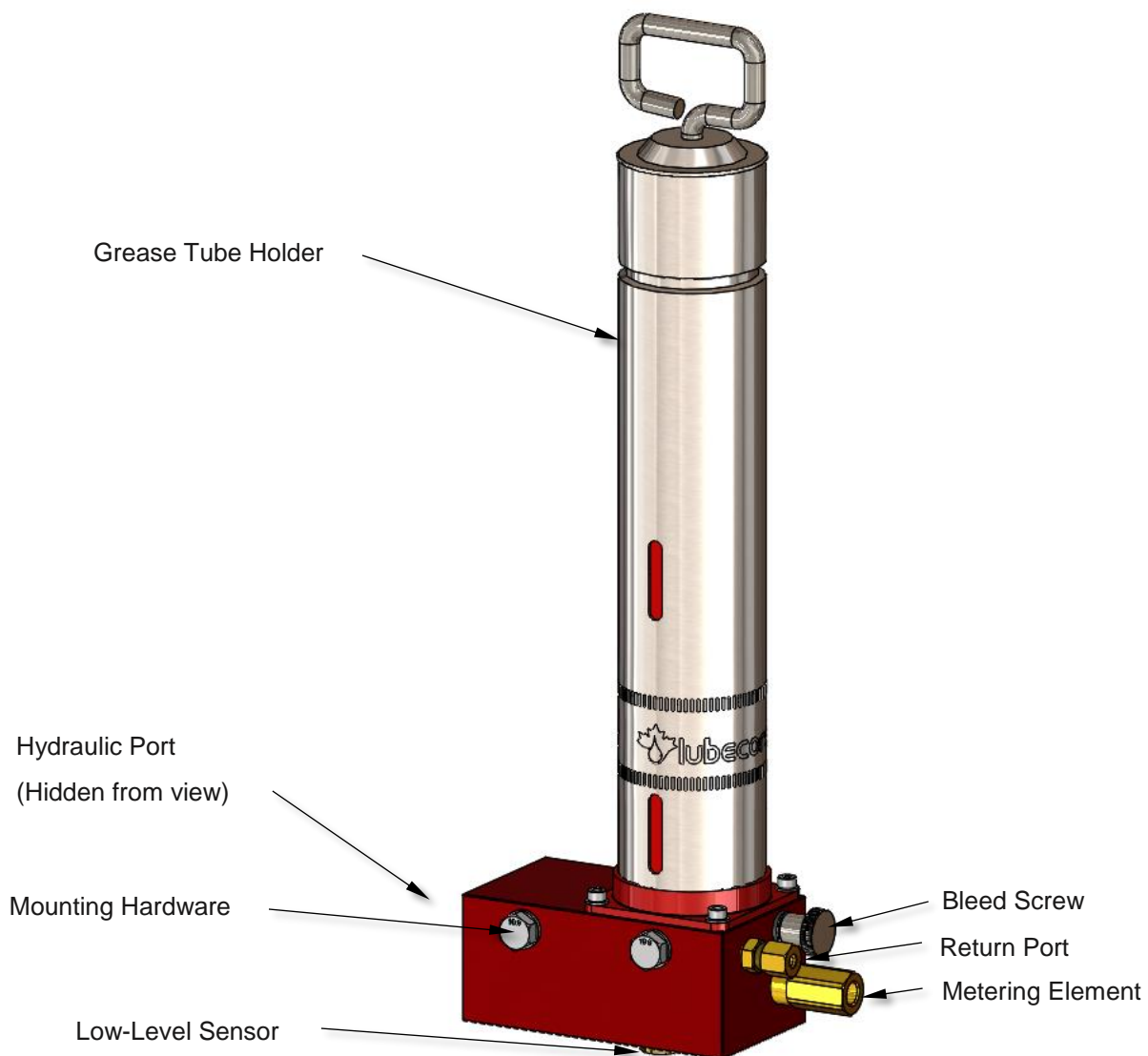

Figure 2

Envelope

The envelope dimensions of a typical pump unit are shown in **Figure 3**. The size of this grease pump is very similar to a handheld manual grease gun allowing for compact installations. Note the grease tube spring compression rod extension envelope that must be accounted for in the installation.

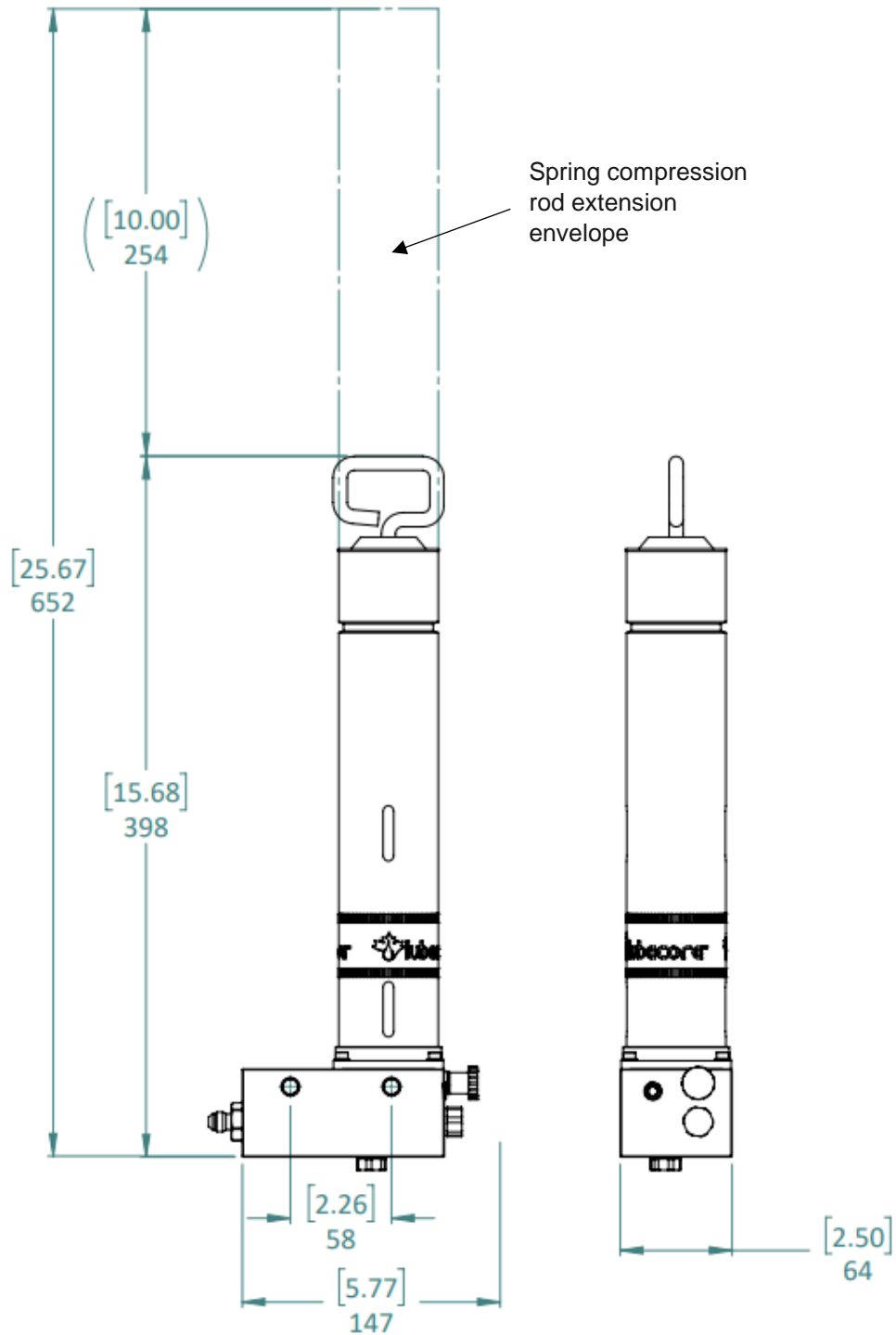

Figure 3 Envelope Dimensions

Operating Principle

Hydraulic pressure enters the hydraulic inlet fitting shown on the left side of the pump. The pressure actuates the grease metering element which delivers a preset volume of grease. This grease flows to a distribution block which progressively channels the flow to the grease points. Once hydraulic pressure is relieved, internal energy storage in the pump pushes the hydraulic fluid back to the machine and the metering element reloads with grease for the next application of hydraulic pressure. The operator can monitor the grease levels within the system through the grease level viewports. This monitoring can also be achieved by installing a low-level warning light in an easy to notice location with the equipment cab that would be turned on by the low-level sensor in the bottom of the grease pump. When the grease tube needs to be replaced, the operator unscrews the tube carrier and replaces the tube of grease in the same manner as replacing a grease tube in a manual grease gun. Once a fresh grease tube is installed into the grease pump, the operator opens the bleed screw in the side of the pump and allows any air trapped under the new grease to escape. With the system bled and bleed screw turned back in, the system is ready to continue greasing.

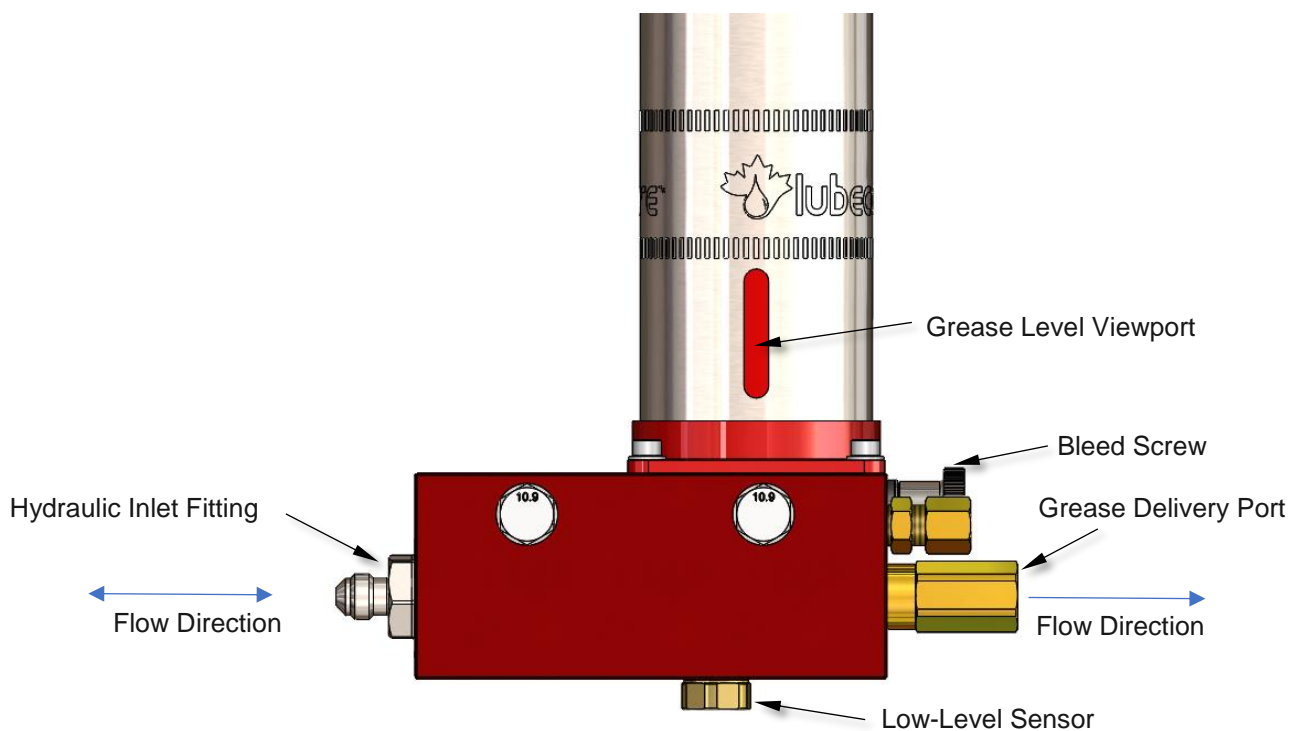

Figure 4: General Operating Schematic

Unlike most Automated Lubrication Systems which are electrically powered, this lubrication system relies only upon hydraulic inlet pressure. Therefore, it only greases when the equipment is in use, not while the equipment is idling. This makes the system a good fit for equipment with intermittently used features. For example, the front-end bucket on a backhoe is typically not in use when the hoe is in use. The liftgate on a delivery truck or the crane on a mobile crane or crane truck is not in use while the truck is travelling. A front-end loader on a farm tractor is not in use while the tractor is simply pulling equipment. The refuse packer on a garbage truck is only used periodically as the truck is filled. It is also well suited to small applications such as mini-excavators, skid steers or other similar equipment.

Platform Interfaces & Requirements

Hydraulic Pressure Requirements

The hydraulic grease pump is driven by vehicle hydraulic pressure. It typically needs 1000 psi (70 bar) inlet pressure to function well. Small excavation equipment hydraulic systems typically run at 3500 psi (240 bar) max. This is more than sufficient to run the pump. **Table 1** provides pressure information.

Table 1 – Operating Pressures

Condition	Pressure (psi)	Pressure (bar)
Min. return to tank pressure generated by the pump	80	5.5
Min. full stroke pressure	640	44
Recommended min. system operating pressure	1000	70
Max. system operating pressure	3500	310

In the rare occurrence that the system is installed on a piece of equipment that generates less than 1500 psi (100 bar) max, the actuator return spring in the pump can be replaced with a lighter spring to allow the pump to function correctly. In this case, the operating pressures are shown in **Table 2**.

Table 2 – Operating Pressures

Condition	Pressure (psi)	Pressure (bar)
Min. return to tank pressure generated by the pump	40	2.25
Min. full stroke pressure	320	22
Recommended min. system operating pressure	700	48
Max. system operating pressure	3500	310

Figure 5 shows a typical pressure trace from the lift cylinder of a backhoe. The delivery pressure zone and pump reload pressure zone are shown. This example shows a delivery pressure that is above the minimum operating pressure recommendation and below the maximum operating pressure, which is a pressure range that is well suited for the pump operation.

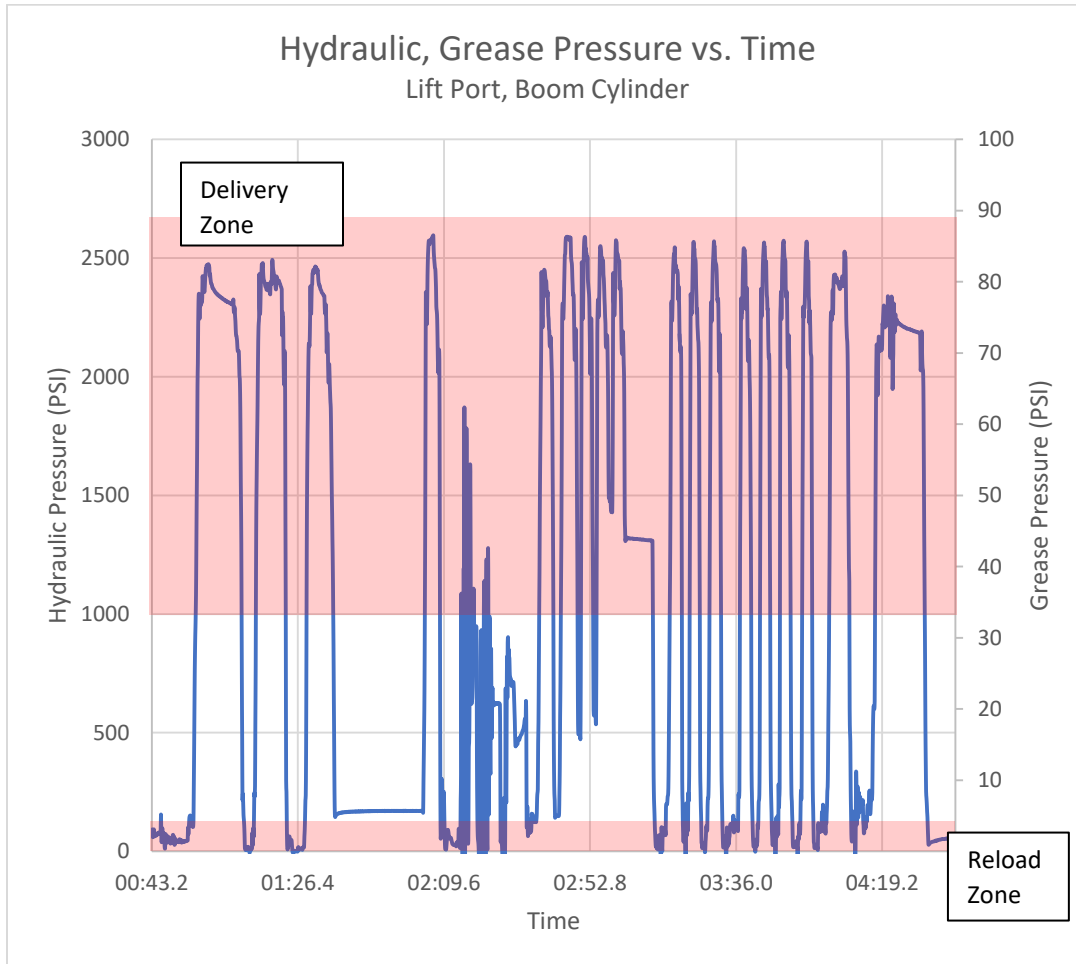

Figure 5 Example Machine Pressure Trace

Hydraulic Interfaces

The hydraulic-powered lubrication system must be connected to the hydraulic system of the platform on which it is mounted. It should be mounted on one side of a two-way cylinder, preferably on the side that generates the most pressure which is typically the lifting side of the cylinder.

Some recommended hydraulic interface points are outlined below:

- Excavator: Boom lift cylinder, lifting end
- Skid Steer: Arm lift cylinder, lifting end
- Tailgate: Lift cylinder, lifting end



Figure 6 Gauge Port Adapter

A JIC gauge port adapter as shown in **Figure 6** would typically be used to tie into the hydraulic system. The gauge interface port becomes the hydraulic line connection point for the grease pump. Other fittings are available from Lubecore in cases where the equipment is not equipped with JIC fittings.

Inlet Hose

The pump hydraulic interface features a #4 Male JIC fitting. A hydraulic hose should be used to plumb the hydraulic fluid to the pump. See the *Illustrated Parts List* for more details. The operator can add hydraulic inlet or grease outlet pressure monitoring equipment as desired.

Mounting Interfaces

The pump mounting holes shown in **Figure 7** offer three mounting options. They will accept M8 and 5/16" through bolts and feature M10X1.5 blind threads on both sides of the pump which are 20mm deep. If M10 fasteners are used to mount the pump to a bracket or machine, no nuts are required. However, if M8 or 5/16" through hardware is used, nuts will be required to fasten the pump into place. Keep the nut on the pump side of the interface to ensure a consistent bolt head protrusion on the bracket side of the interface as shown in Error! Reference source not found..

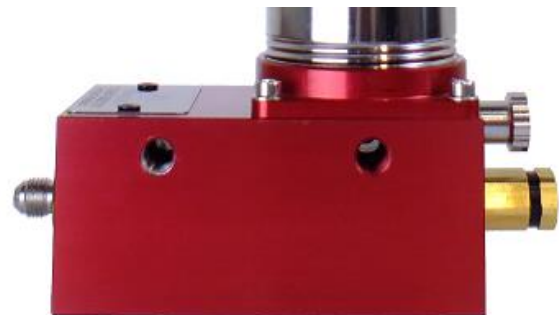

Figure 7 Mounting Holes

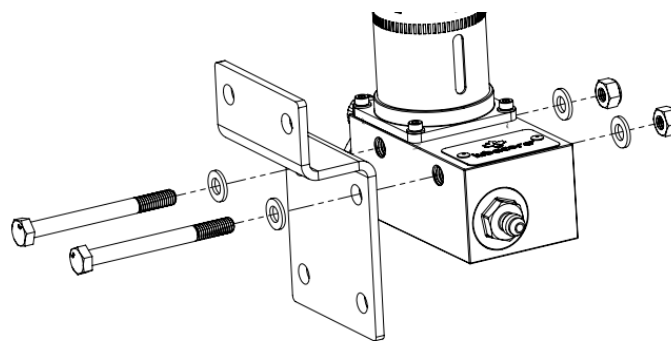

Figure 8 Bolts on Bracket, Nuts on Pump

Lubecore recommends the use of an anti-seize compound when installing the mounting hardware. NoAlOx from Ideal Industries is a recommended anti-seize compound for this application. A picture of typical NoAlOx containers is shown in **Figure 9**.

Band clamps may be used to mount a pump mounting bracket directly to a cylinder if so desired. This provides a compact mounting option (**Figure 10**).



Figure 10 Band Clamps with Mounting Brackets on Cylinder



Figure 9 NoAlOx Containers

Optional Low-Level Sensor

The pump can be equipped with a low-level sensor. The low-level sensor can be found on the bottom of the pump, opposite the grease tube. Once the internal grease tube sealing assembly reaches the minimum grease level, the low-level sensor's ground signal is activated, providing a ground path for a low-level light to turn on. This alerts the operator that the grease tube is empty and requires refilling.



Figure 11 Lubecore 12.097 Low-Level Sensor

Wiring Schematic

The wiring for the low-level sensor, shown in **Figure 12**, includes a light, low-level sensor and harness. The black wire from the low-level sensor is the ground signal needed to switch the light on. The brown wire from the vehicle positively powers the sensor and the blue wire provides the sensor ground. The red wire to the light is the power feed to the light. The harness is provided with enough length of black and red wire to allow for light installation location varying from one piece of equipment to another.

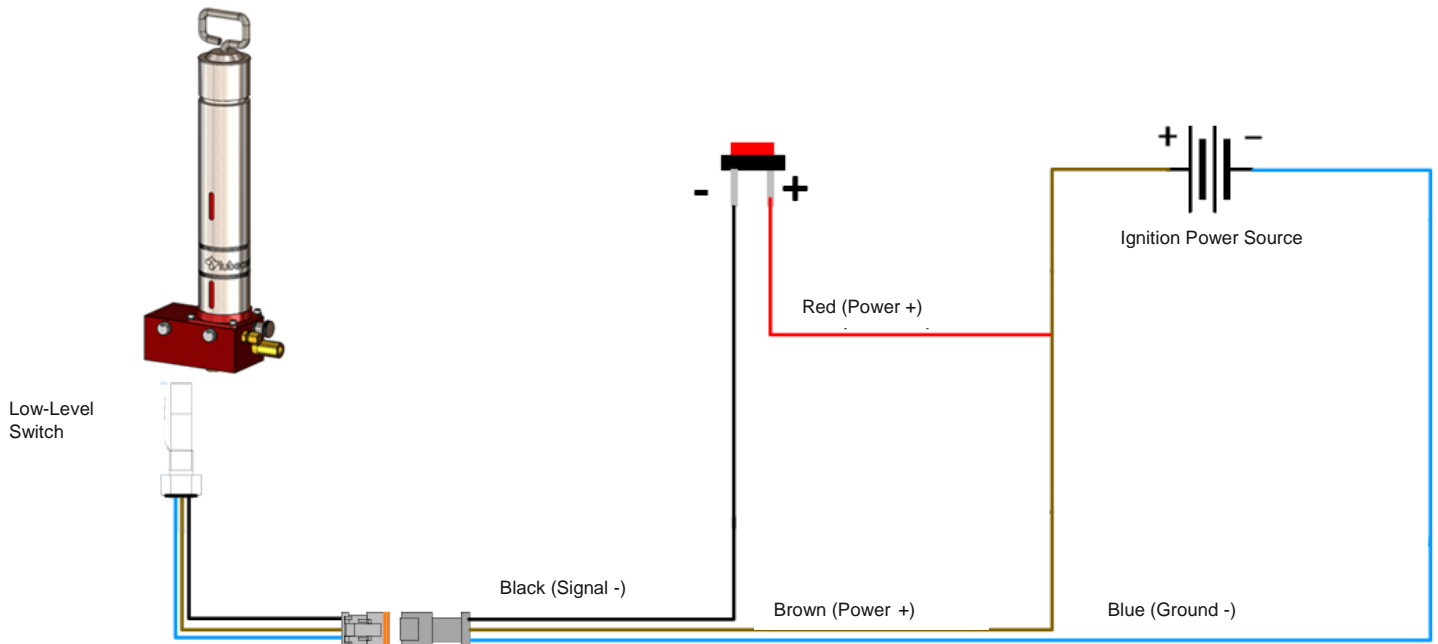

Figure 12 Low-Level Wiring Schematic

Metering Element Sizing

The hydraulic-powered Automated Lubrication System delivers grease every time the hydraulic port is plumbed to be pressurized. The system will deliver grease more often than a timer-controlled system. To determine the element size required for the hydraulic system apply the formula below.

$$Element_{size} = \frac{Progressive_{system}cc/hour}{Hydraulic\ Strokes/hr}$$

The element sizes available for this system are shown in **Table 3**.

Table 3 Metering Element Sizes

Element Color Identification	CC's/Stroke
Brown	0.01
Red	0.02
Black	0.04
Green	0.06
Yellow	0.08

The suggested cc/hour used by various pieces of equipment is shown below in **Table 4**.

Table 4 Suggested CC/hr

Equipment	CC/hour	Equipment	CC/hour
Mini-Excavator	4 to 6	Skid Steer	2
Backhoe Total	6 to 8	Refuse Packer	4 to 8
Backhoe Back End	4	Lift Gate	2 to 3
Backhoe Front End	4	Truck Mounted Crane	4 to 6

Using mini excavator as an example, from **Table 4**, enter 6cc/hour as the grease requirement. If the hydraulic system is plumbed into the lifting side of the boom cylinder and assuming the operator digs into the hole 4 to 6 times/min for an average of 5 times/minute or 300 times/hour the element size requirement is as follows:

$$\frac{6cc/hour}{300\ cycles/hour} = 0.02cc/stroke$$

From **Table 3**, a red element would be a great starting point for the system. As this lubrication system only greases when the equipment is in use Lubecore recommends the selection of elements to be biased towards a heavier grease application as this system will generally give less grease than a timer-controlled system if it were designed to give the exact same cc/hour as an electrically driven progressive system. If the calculation suggests using a red element as shown in the example, it would be recommended to start the installation with a black element.

Lubecore strongly recommends that the grease requirements of the manufacturer are followed when selecting the element size. **Table 4** gives some suggested starting points for what typical systems may use, however, grease requirements are typically based on the size of equipment, the number of grease points to be lubricated, and the machine's working environment.

Greasing System Output Pressure

The elements used with this pump are taken from the Lubecore Multiline Pump series. These elements can generate pressures of over 3000 psi (207 bar) which is the pressure at which Lubecore sets the pressure relief valve for all progressive systems. Typical progressive system operating pressures are 300 to 1500 psi (20.7 to 100 bar)

Pressure Relief Valve

If a customer wishes to have a pressure relief valve, the progressive system pressure relief valve Lubecore provides can be installed as an option. This valve will limit the system pressure to 2900 psi (200 bar).

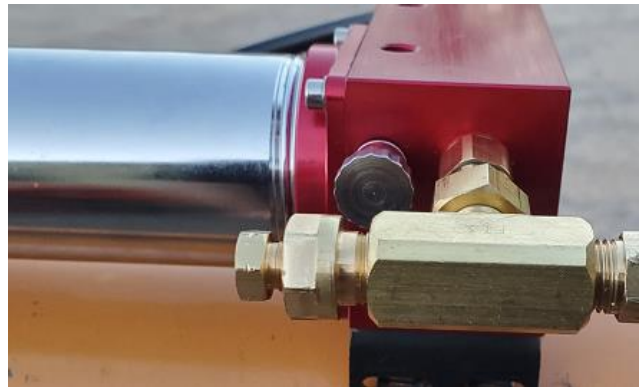

Figure 13 Pressure Relief Valve on Pump Outlet

System Layouts

An example of a system layout for a skid steer loader is shown in Error! Reference source not found.. Lubecore can provide system layouts as needed for the installation of hydraulic-powered progressive Automated Lubrication Systems as needed which will have the same form as the example shown.

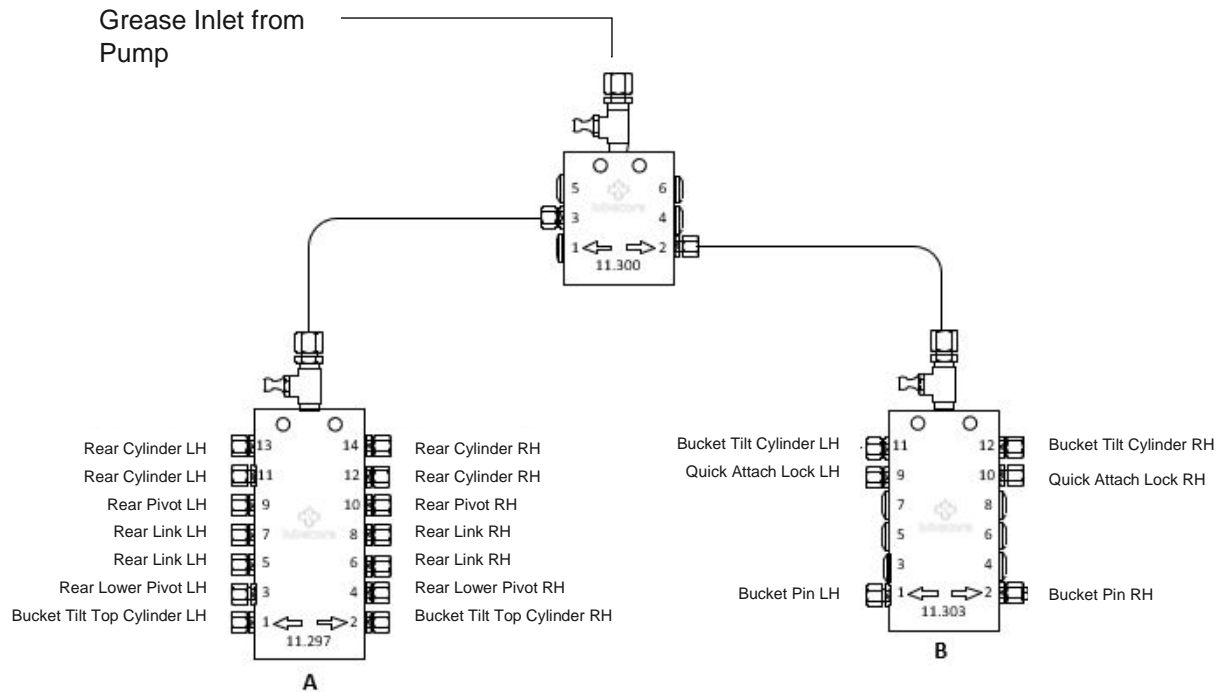

Figure 14 Skid Steer Progressive Distribution Layout

System Size Limitations

Like all Lubecore progressive systems, there is no size limit to the distribution system attached to this hydraulic-powered pump. Most systems using this system would have 25 points or less. Keep in mind that a standard tube of grease is 400g and therefore, the larger the system the quicker the tube of grease will need to be replaced. The installer should determine the approximate replacement time for the grease tube based on the machine's usage rate to determine if the grease tube replacement is considered acceptable to the customer. If the replacement interval is too short for the customers liking, a larger system such as Lubecore's 2kg or 4kg systems should be considered.

Installation Guide

1. Determine the pump mounting location.
 - a. The location must allow for a grease tube to be removed and installed from the pump. (See Envelope and Maintenance Sections)
 - b. The location must not interfere with machinery movement. An example is shown in **Figure 15**. The pump is easily identifiable, and there is easy access to the grease tube.
 - ✘ Do not mount in an area where machinery movement could strike the pump. on a lift gate cylinder where a folding lift gate would strike the grease pump.
 - ✘ Do not mount in a location that would prevent the grease tube from being removed.



Figure 15 Pump Installed in Skid Steer Engine Compartment



Figure 16 Mount on Cylinder Access all Around

2. Install mounting brackets
 - a. Note: if the pump is being installed on the machine and not a cylinder, drilling may be required.
3. Install the pump onto the mounting bracket. Ensure the viewport windows showing the grease level in the pump are visible.

Notes:

- ❖ Sets two and three do not need to be done in exact order. Install in the order most efficient.
- ❖ It is recommended when using a through bolt pump mounting kit to keep the nut on the pump side of the interface. This will ensure that the protrusion of the bolt from the nut will not interfere with the machine when using a low-profile bracket.
- ❖ The grease tube to pump adapter is held onto the pump with an adapter. This adapter can be rotated in 90° increments and installed back onto the pump allowing the installer to ensure the grease tube viewports are visible after installation.
 - Screw the grease tube snugly into the pump.
 - Check the viewport orientation
 - Change the tube adapter orientation as needed. (Illustrated in **Figure 17**)

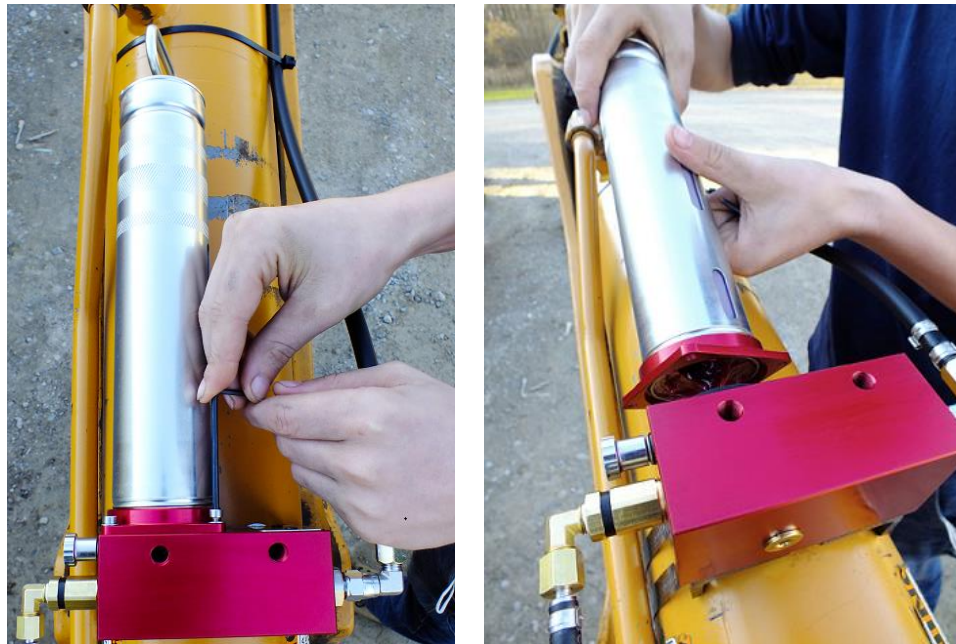

Figure 17 Rotating the Grease Tube Making the Viewports Visible

4. Install the gauge port adapter (**Figure 18**) into the lift side pressure line of the cylinder. Reconnect the hydraulic supply to the cylinder through the gauge port fitting and install a hydraulic feed line to the hydraulic-powered automatic lubrication pump.

Notes:

- The typical maximum hydraulic pressure on excavating equipment is 3500 (240 bar).
- The maximum rest pressure in the hydraulic system that will allow the pump to reload is 80 psi (5.5 bar). There is no time requirement for the system to reach or stay below the reload threshold.

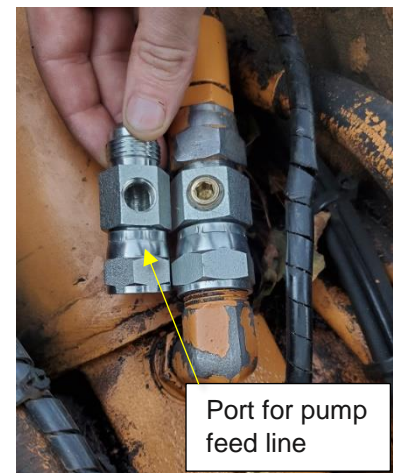

Figure 18 Gauge Port Adapter

5. Note the examples of the lift side of the cylinder shown below in **Figure 19**: Although the lifting side is typically opposite the rod end of the cylinder, it is the installer's responsibility to ensure that it is. The grease pump hydraulic inlet may be plumbed to the downstroke side of the cylinder as well; however, it is recommended to ensure the pressure profile on the downstroke is known. (See **Figure 5**).



Figure 19 Lift side of cylinder on various equipment examples

6. Crack open the #4 JIC nut from the hydraulic inlet fitting on the lubrication pump for bleeding purposes (See **Figure 20**).
7. Cycle the hydraulic cylinder until hydraulic fluid escapes from around the JIC nut.
8. Torque the #4 JIC nut onto the inlet fitting to 11 to 13 ft-lb (15 to 17.5 Nm)
9. If required, replace the element in the pump with the element desired for the application (note, a black element comes standard with the pump).



Figure 20 Bleed Hydraulic Inlet

10. Loosen the grease bleed screw in the pump (**Figure 21**).
11. Install a new tube of grease into the hydraulic pump ensuring to unlock the central spring compression rod in the grease tube housing after the housing has been installed.
12. Allow grease to ooze out of the grease bleed port as shown in **Figure 21**. Once fresh grease is flowing from the bleed port, tighten the bleed screw and wipe the excess grease from the pump.
13. Cycle the lift cylinder so that the pump is plumbed up and down until grease is being delivered from the grease element.
 - a. Note: As more load is applied to the cylinder, more pressure will be present in the cylinder inlet line which is connected to the grease pump. Generating sufficient grease pump driving pressure on a new install can be achieved by either lifting a load such as a full bucket or bringing the cylinder to its full stroke and lifting against the cylinder stops.
14. Connect the pump at the grease element to the progressive distribution mainline as shown in **Figure 22**.



Figure 21 Bleed Screw

Optional equipment installation:

15. Install the low-level light in the equipment cab in an easy-to-see location.
16. Install the low-level harness. Connect it to an equipment power ground source and plug the harness into the light and low-level sensor. Neatly coil and secure any excess harness length in a safe location.
17. Install low-level light indicator sticker.
18. Cycle the system several times looking for evidence of fresh grease at the points connected to the Automated Lubrication System.

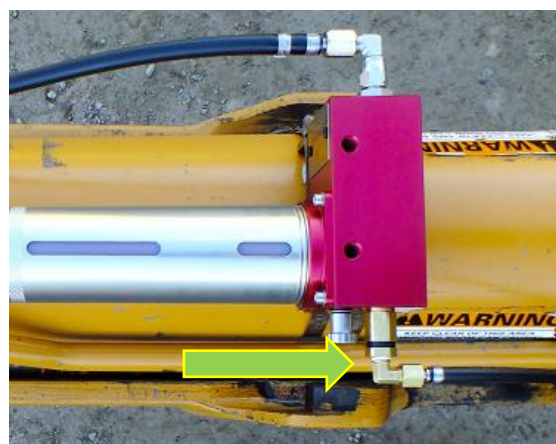

Figure 22 Connect Mainline to Element

Mounting Bracket Options

Lubecore offers four bracket options to mount this pump:

1. Low-Profile Standard Bracket
2. High-Profile Bracket
3. Cylinder Mount Bracket
4. Weld-On Bracket

Low-Profile Standard Bracket

The low-profile standard bracket is designed to allow multiple mounting configurations. It can be attached to the pump using M8, 5/16, or M10 bolts. It can be mounted to the equipment with M8, 5/16, or M10 bolts. Pictures of some potential mounting options using this bracket are shown in **Figure 23**. If M8 or 5/16 hardware is used to mount the pump to the bracket, the bolts used must go through the pump and be fixed in place with a nut on the opposite side of the pump as shown in **Figure 24**.



Figure 23 Z-Bracket Orientations



Figure 24 M8 and 5/16 Bolt Configuration (Left) compared to M10 Bolt Configuration (Right)

High-Profile Standard Bracket

The high-profile bracket features the same mounting flexibility as the low-profile standard bracket with the added benefit of allowing the pump to be offset a little more from the mounting point. This bracket may be used if the installer is installing the bracket over something like a hydraulic or electrical bundle on the machine. The high-profile bracket offers a 38.1mm (1.5in) offset from the installation plane; whereas the low-profile bracket offers a 12.7mm (0.75in) offset from the installation plane.



Figure 25 - Low-Profile to High-Profile Bracket Comparison

Cylinder Mount Brackets

The cylinder mount brackets are configured to be used in pairs. **Figure 26** shows how these brackets can be configured. The open slots in the brackets are to be used to feed standard gear drive hose clamps through to fasten the pump to a cylinder or any other structure that hose clamps can be fit around.

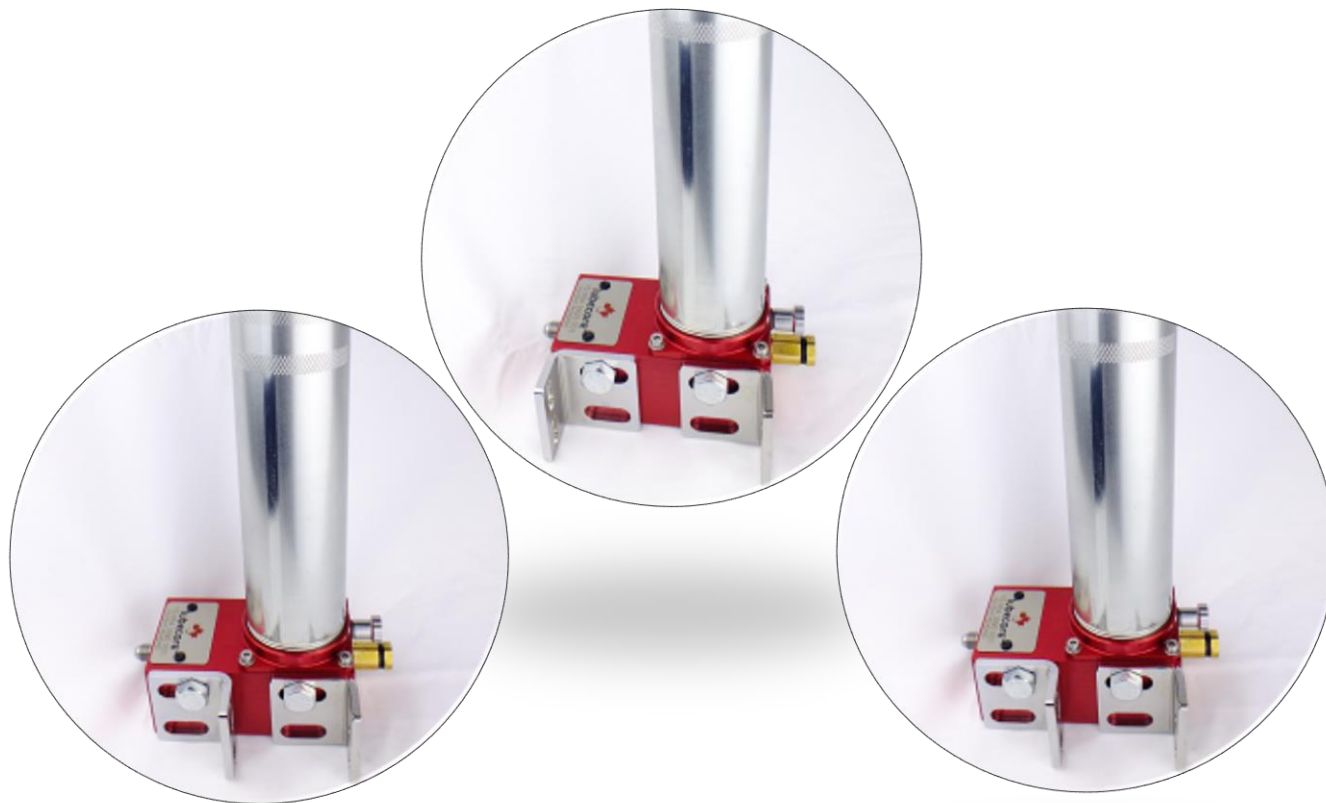

Figure 26 Cylinder Bracket Mounting Configurations

Weld-On Plate

The weld on plate with associated hardware is shown in **Figure 27**.

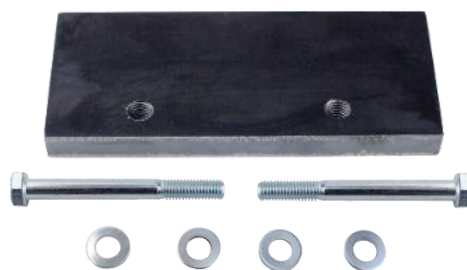

Figure 27 Weld on Plate

Maintenance Procedure

1. The grease tube in the canister must be replaced when empty. The two methods for determining if the grease tube is empty are as follows:
 - a. Look through the viewport in the canister to determine grease level (Requires see-through grease tubes, available from Lubecore)
 - b. Low-level light comes on. (Low-Level Sensor must be installed)
2. Remove the grease tube canister from the pump.
3. Pull the canister spring compression rod out to its fully extended position and lock it in place.
4. Remove the grease tube from the canister.
5. Install a new grease tube into the canister.
6. Remove the pull tab cover from the grease tube.
7. Install the canister back onto the pump.
8. Unlock the canister spring compression rod and press it down into the canister.
9. Open the bleed screw in the side of the pump. Allow any air trapped in the pump after the installation of the new grease tube to escape. Once the air has escaped, tighten the bleed screw and wipe any excess grease from the side of the pump.
10. Check the pump for any leaks or other signs of damage.
11. If the system is installed with a low-level light, the light should be off.



Figure 28 Empty Grease Tube



Figure 29 Removing empty grease tube

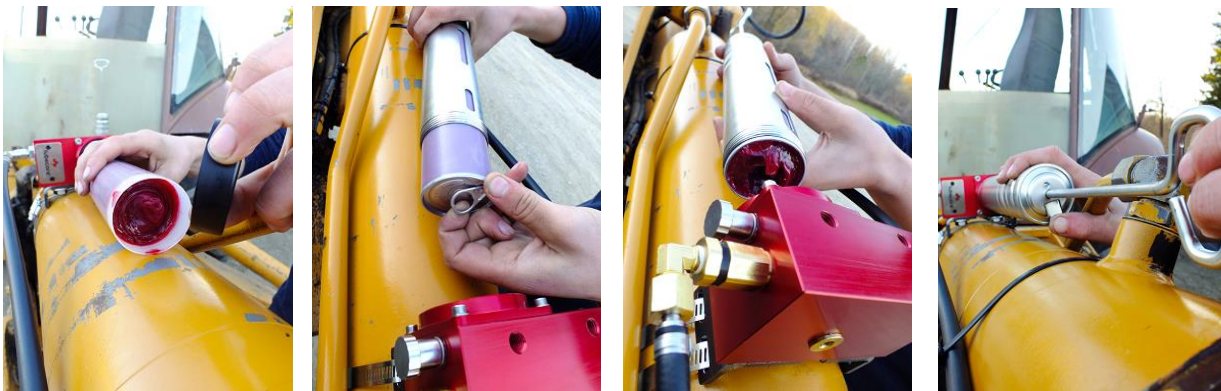

Figure 30 Installing Fresh Grease Tube

Trouble Shooting a Progressive Automatic Greasing System

If the Automated Lubrication System is not delivering grease through the progressive distribution system, there may be blockage at a grease point on the machine the system is installed onto. A blockage in the system generally indicates that the machine itself may have an issue that needs to be addressed as something in the bearing area where grease is to be delivered is malfunctioning.

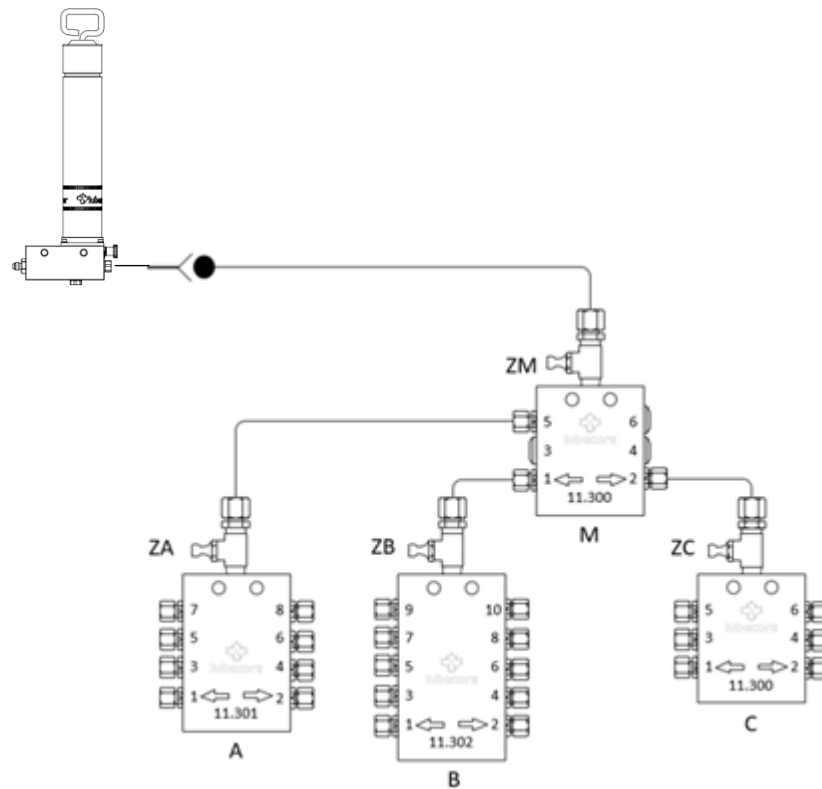

Figure 31 – Generic Progressive Distribution System

Figure 31 shows a generic progressive system. The labels in **Figure 31** are referred to below in the generic progressive system troubleshooting guide.

1. Leave the system under pressure
2. Go to secondary valves A, B, and C with a manual grease gun equipped with a pressure gauge.
3. Check valve A by manually pumping grease into zerk ZA. The valve should shuttle and dispense grease. If the valve is not shuttling, remove the secondary lines one at a time until the block begins to shuttle under the influence of the manual grease gun. The blockage in the system is at the end of the line last removed from the block before it began shuttling. The joint at the end of the grease line must be freed up to allow grease to flow into it again.
4. Repeat step 3 for valves B and C.
5. If all the lines are removed from a valve and it still will not shuttle, the valve is clogged and requires replacement.
6. If the secondary valves A, B, and C are shuttling freely, the blockage is in the main valve M.
7. Remove the grease lines from valve M that feed valves A, B, and C one at a time to confirm it is not a blocked line. Replace any blocked lines found.
8. Replace valve M if no blocked lines are found in step 7.

9. Note: Lines should be removed at the check valve by removing the line ferrule compression nut, not the fitting at its base. If check valves are removed from the base inadvertently, they must be reinstalled and torqued to 95 to 100 in-lbs (10.7 to 11.3 Nmm). There should be no leaks between the valve outlet check valves and the valve body after installation.

Available Options

The options for a hydraulic-powered Automated Lubrication System with reasons for their inclusion in an installation kit are outlined in **Table 5**.

Table 5 Installation Options

Option	Reason for Inclusion
Pressure Relief Valve	Gives an early warning to the operator that there is a blockage in the greasing system. Blockages are typically caused by problems at the greased location such as an overly tight bearing.
Hydraulic Inlet Pressure Gauge	Quick reference for the pressure feeding the Automated Lubrication System.
Grease Outlet Pressure Gauge	Quick reference for the greasing system resistance pressure.
Return to tank fitting	For system delivery fine tuning, some grease may be returned to the pump reservoir (grease tube).
Korilla Lining	Allows pressure in lines to operate as high as 3500 psi (240 bar). Lines will not burst before a pressure relief valve.
Low-Level Sensor Kit	A low-level light can be installed to provide in-cab notification to an operator that the lubrication system is empty.

How to Order

Option 1

Contact Lubecore Inside Sales Representatives to generate a custom kit for your specific installation. This is the recommended option when a customer is installing many identical systems on a fleet of vehicles. This allows the customer to order one part number and receive everything needed to complete a system install in one package.

Option 2

Step	Item to Order	Lubecore Part Number(s)
1	Order base pump unit	10.864
2	Order the desired mounting brackets and hardware kits	See Illustrated Parts List
3	Order the desired hardware kits	See Illustrated Parts List
4	Order hydraulic line kit	See Illustrated Parts List
5	Order gauge port fittings ¹	See Illustrated Parts List
Optional Equipment Order		
6	Order optional elements if required	11.601, 11.602, 11.604, 11.606, 11.608, 11.610, or 11.612
7	Order low-level kit	54.387
8	Order optional equipment	Pressure Relief Kit: 54.354 Pressure Gauge(s): 10.545 Return to Tank Fitting: 20.022
9	Order distribution system	Speak with Lubecore Inside Sales Rep*

* Lubecore has distribution system bills of material for most mobile equipment on the market around the world. The information Lubecore inside sales would need regarding your installation is the make and model of the equipment in question. If a system layout is not available for that vehicle, the inside sales rep will determine with the customer the number of grease points, where they are located on the equipment, and apply an appropriate grease distribution system based on the information provided.











¹ When installing a system on a new piece of equipment it may not be known what the JIC fitting size that will be teed into at install. It is recommended to carry the full range of gauge port fittings to the install to ensure the right size is available when needed.

Illustrated Parts List

Table 6 provides an overview of the parts and kits available for installing a hydraulic-powered Automated Lubrication System.

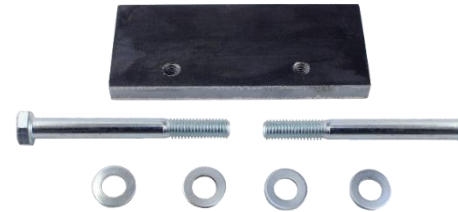
Table 6

Description	Part Number	For use with	Part	Includes
Pump	10.864	Parts Below		Hydraulic-Powered Automated Lubrication Pump
Pump Sub Assembly	15.009			Pump Sub Assembly
Low-Level Sensor Kit	54.387	10.864		<ul style="list-style-type: none"> • Low-Level Sensor Harness • Warning Light • Warning Light Indication Sticker • Wiring Schematic
Low-Level Sensor	12.097	10.864		Low-Level Sensor
#4 JIC 90° Swivel Fitting	21.137	Part of 54.386		#4 JIC 90° Swivel Fitting
#4 Gauge Port Fitting	21.138	54.386		#4 Gauge Port Fitting
#6 Gauge Port Fitting	21.139	54.386		#6 Gauge Port Fitting
#8 Gauge Port Fitting	21.140	54.386		#8 Gauge Port Fitting
#10 Gauge Port Fitting	21.141	54.386		#10 Gauge Port Fitting
#12 Gauge Port Fitting	21.142	54.386		#12 Gauge Port Fitting

#4 O-Ring Face Seal Adapter	21.147			#4 O-Ring Face Seal Adapter
#6 O-Ring Face Seal Adapter	21.148			#6 O-Ring Face Seal Adapter
#8 O-Ring Face Seal Adapter	21.149			#8 O-Ring Face Seal Adapter
#10 O-Ring Face Seal Adapter	21.150			#10 O-Ring Face Seal Adapter
8mm Through Bolt Pump Mounting Kit	54.372	10.864 40.298 40.299 40.300 54.375		<ul style="list-style-type: none"> • 8mm bolts • 8mm washers • 8mm nuts
10mm Bolt Pump Mounting Kit	54.373	10.864 40.298 40.299 40.300 54.375		<ul style="list-style-type: none"> • 10mm bolts • 10mm washers
8mm Weld-On Pad Pump Mounting Kit	54.374	10.864		<ul style="list-style-type: none"> • Weld on mounting plate • 8mm bolts • 8mm washers
Bracket to Vehicle Mounting Kit	54.375	40.298 40.299 40.300		<ul style="list-style-type: none"> • 10mm bolts • 10mm washers • 10mm nuts
Brown Element	11.601	10.864		Element Assembly
Red Element	11.602	10.864		Element Assembly
Black Element	11.604	10.864		Element Assembly

Green Element	11.606	10.864		Element Assembly
Yellow Element	11.608	10.864		Element Assembly
Red Spring	15.012	10.864		Spring
Gold Spring	15.003	10.864		Spring
Hose Ass'ly 10' x 1/4" ID Korilla FJICSW - Filled	54.335			<ul style="list-style-type: none"> • Filled Korilla Hose • Insert and Swivel Nut • Clamp
Steel Braided Hydraulic Hose 10', Hydraulic Pump Kit	57.646			<ul style="list-style-type: none"> • Steel Braided Hose • Reusable
Cylinder Mounting Bracket	40.298	10.864 54.372 54.373 54.375		Cylinder Mounting Bracket
Bracket, Hydraulic Pump "Z" Bracket, Short	40.299			Low Profile Z Mounting Bracket
High Profile Z Mounting Bracket	40.300	10.864 54.372 54.373 54.375		High Profile Z Mounting Bracket
Stainless Steel Gear Clamp 2-7 inch Surelock	41.327			Clamp

Stainless Steel Gear Clamp 7.75-11.75 inch Surelock	41.328			Clamp
NoAlOx Paste	15.010			½ oz anti-corrosion paste
#4 BSP Adapter	21.151			#4 BSP Adapter
#6 BSP Adapter	21.152			#6 BSP Adapter
#8 BSP Adapter	21.153			#8 BSP Adapter
Low-Level Sensor Harness	50.959	12.097		Low-Level Sensor Harness
Grease Tube	31.111	10.864		Grease Tube

Trouble Shooting Guide

The table below provides trouble shooting direction to determine how a hydraulic-powered Automated Lubrication System may be malfunctioning.

Problem	Diagnosis / Check Item	Solution
Pump soes not deliver grease	Check grease level	Look through the grease level viewport if using transparent grease tubes, review the low-level light status, or open the grease tube and check the grease level. Refill if empty.
	Check hydraulic inlet pressure. Ensure it is above 1000 psi (70 bar)	If inlet pressure is too low, move the hydraulic feed to a higher pressure line, or contact Lubecore for a lighter actuator spring.
	Ensure the element actuator is moving. Remove the grease metering element and cycle the system with small tool inserted into the element hole and resting on the actuator	If the actuator is not moving, it is likely mechanically jammed in the assembly. Remove and inspect the actuator by removing the hydraulic inlet fitting. If there is internal damage to the inlet fitting or actuator, replace both parts.
	Check for air in the system	First crack open the bleed valve to allow any air trapped under the grease tube to escape. Next remove the grease metering element and allow a little grease to flow out of the metering element hole along with any trapped air.
	Check output pressure level	If the grease output pressure level is above 3000 psi (207 bar), there is excessive resistance or a blockage in the system. Refer to § <u>Maintenance Procedure</u> for the procedure required to find a system blockage. Repair the equipment as necessary.
Low-level light remains on after grease tube has been replaced	Check for wear in the low-level harness. Verify that there isn't a ground signal present when the grease level is full	Replace worn low-level harness.
Hydraulic fluid in grease chamber	Check wear on element actuator seals	Replace worn seals.



lubecore™

NEXT GENERATION AUTOMATED LUBRICATION

Head-office:

Lubecore International, Inc.

7065 Twiss road

Campbellville, Ontario

Canada L0P-1B0

Phone: 1-905-864-3110

E-mail: Info@Lubecore.com

Web site: <http://www.lubecore.com>

