

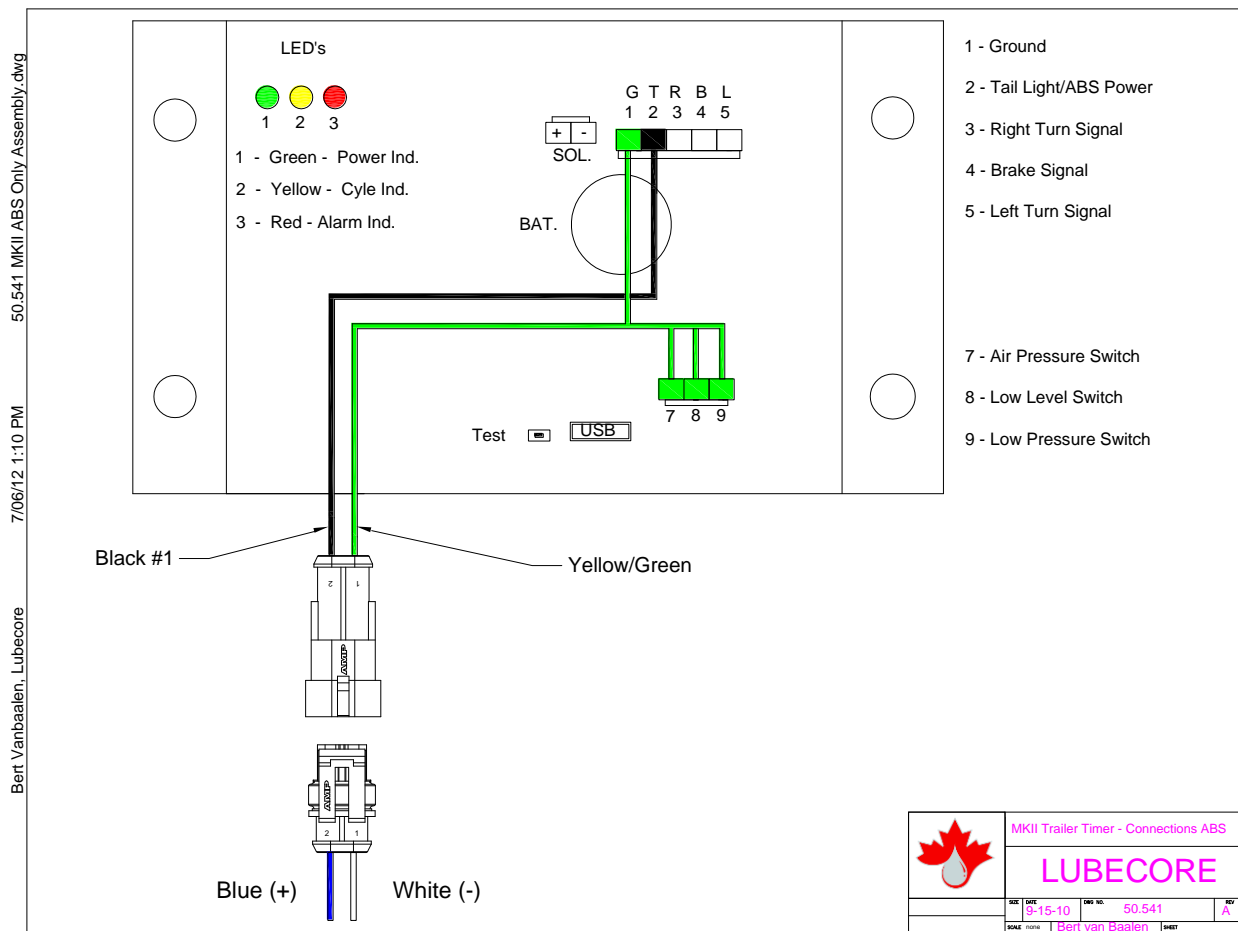

## Alternative Trailer Timer Wiring Method - Bulk Fuel Trailers with Fill Sensor System

Below is a drawing of the Trailer Timer Standard ABS Wiring Method – Blue wire connected to center pin – blue ABS wire. White wire to white ground wire.





Below is a drawing of an alternative wiring method that can be used if there is no ABS or if the end-user decides to change wire connections to accommodate their needs. In this case the customer needs constant battery power to power up the fill sensor system. The center pin ABS connection is now only supplying battery power to the fill sensor system. In order for the ABS System to still operate, they've chosen to use the red wire in the 7 wire harness, which is live with the key turned on.